

2023



THE
HIGHLAND
60

THE HIGHLAND 60



Built for comfort. A 60" wide cabin gives you industry-leading storage and a queen mattress for more room to stretch out.

**GROUND
CLEARANCE**

22"

**TOTAL
STORAGE**

70 CU. FT

**WATER
STORAGE**

36 GAL

**BED
SIZE**

60" x 80"

**CAMPER
DIMENSIONS**

82" x 87" x 196"





SLEEP-IN-CAB COMFORT

The Highland 60 is for those who want to explore deep into the backcountry while enjoying the comforts of a bedroom sanctuary.

All models come with a full kitchen, on-demand water heater, exterior shower, interior & exterior storage compartments, and our premium, in-house designed coil-over suspension system. The interior is made from a sustainable and durable rice husk material that is water resistant and guaranteed not to rot, crack, or splinter. It's the perfect combination of rugged and luxury for those who believe neither should be compromised in the great outdoors.



RUGGED UTILITY

The Highland 60 exterior is designed with more features than a Swiss army knife. Handcrafted with industry leading storage capacity, it boasts an array of strap-down points and (5) water-tight compartments. An available Squatch Box mounts under the roof rack to provide storage for (2) solar panels and (1) custom aluminum camp table.



ADDITIONAL FEATURES



Optional 65 Quart Dual-Zone 12V Fridge/Freezer



Squatch Box Holds (2) Solar Panels & Camp Table



Available Adjustable Side Box Shelving

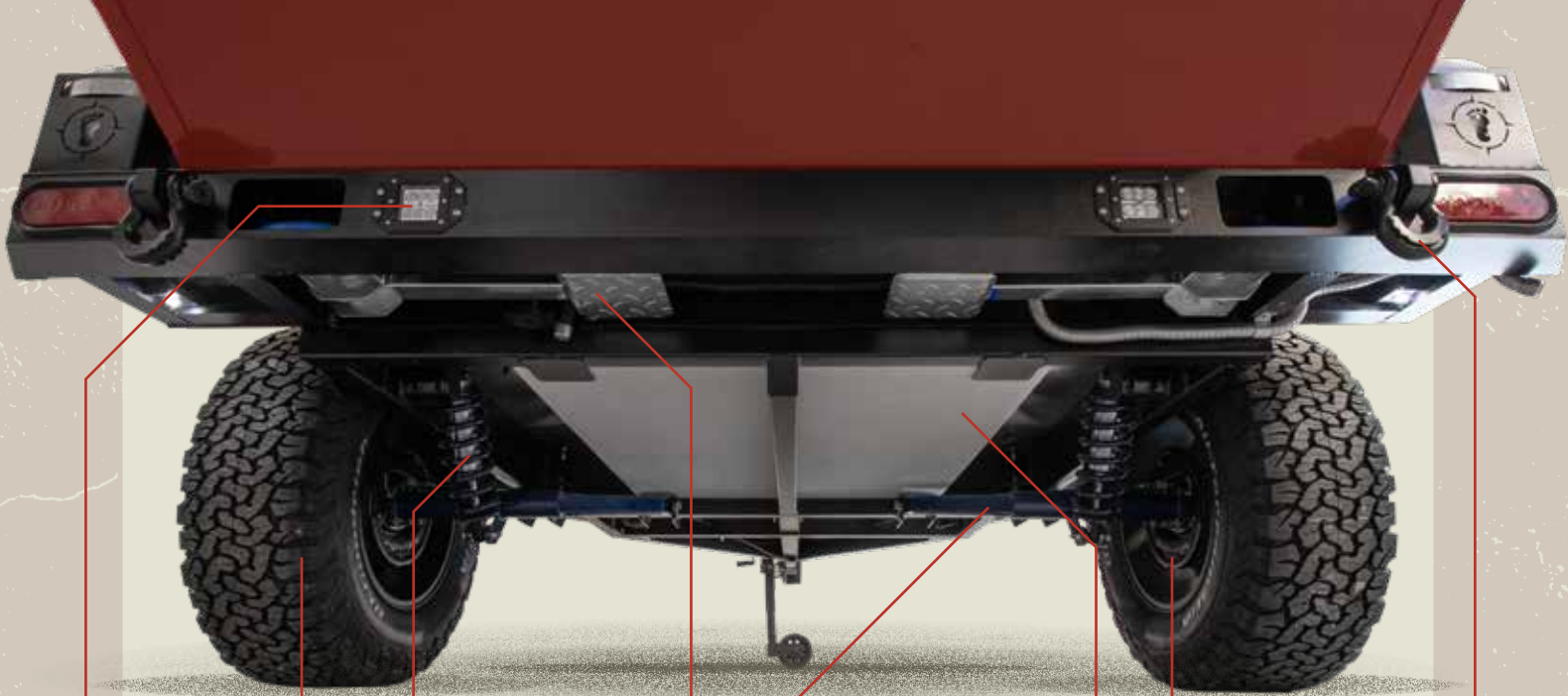

*Adjustable
Fox Coilovers
w/ 5" Of Travel*

*BF Goodrich
K02 285/65/R17
All Terrain Tires*

*Dual Floodlights
w/ Dimmed Reverse Setting*

*In-house Engineered
Independent Trailing
Arm Suspension
System*

*Integrated ARK
Drop-Down Corner
Steadies*

*10" Electric
Brakes*

*36-Gal Thick Wall
Water Tank*

*Dual Recovery
Shackles*

THE FUN BEGINS WHERE THE PAVEMENT ENDS

Built rugged for the rugged, our in-house suspension system is engineered tough.

We believe the road for exploration should not end, so we created a premium suspension exclusively for our products. With Sasquatch, you'll say goodbye to crowded RV parks as you drive by and discover your own destination.

BACKCOUNTRY, GOURMET!

When cooking in the Highland 60, you may forget your miles away from home. With all the amenities and ample storage, meal prepping, cooking and cleaning becomes just as fun as the drive in. An optional door-mounted dual-zone refrigerator swings out of your way as you access a 3-burner propane cooktop, stainless steel sink, cabinets, drawers, interior lights, AC outlet, and water gauge. The optional refrigerator can easily be placed on the ground, giving you even more countertop space. Thirsty? No problem! 36-gal tanks ensure you have plenty of water.

From backcountry grub to gourmet, this kitchen is the perfect recipe.

*Integrated Kitchen Table w/
Available ICECO VL65 Dual-
Zone Fridge*

*Laser Cut Aluminum Triple
Cabinet Storage System
w/ (2) Push-To-Open Drawers*

*Squatch Box Holds (2) Solar
Panels & Camp Table*

ICECO

*Fold-Down Stainless
Steel Prep Table*

*Camp Table That
Folds Into The
Squatch Box*

*Exterior Light Controls
w/ 12V & USB Charge Ports*

*Deep Bowl Sink
w/ Glass Top &
On-Demand Hot Water*



*Control Panel
w/ AC Power
Port*



*Three Burner
7500 BTU
Furrion Cooktop
w/ Electric
Ignition*

BUILD YOUR ADVENTURE

Build your Highland configured how you want it:
[SASQUATCH-CAMPERS.COM/BUILD](https://sasquatch-campers.com/build)

	HIGHLAND 60		
	TRAIL	PRO	PRO-X
	\$49,500	\$54,950	\$59,950
ELECTRICAL			
Renogy 1000W Inverter Charger	x	x	x
Renogy DC-DC Battery Charger	x	x	x
Renogy Battery Monitor w/ LCD Readout	x	x	x
Renogy Battery 200AH	Gel	Gel	Lithium
Rear Exterior USB & 12V Power Supplies	x	x	x
110v Access Point In Kitchen, Cabin, & Tongue Box	x	x	x
200W Renogy Solar Charging System		x	x
KITCHEN			
Aluminum Cabinet Storage System	x	x	x
Stainless Steel Countertop & Backsplash	x	x	x
Galley Lighting	x	x	x
Furrion 3-Burner Cooktop	x	x	x
Sink w/ Fold Down Lid	x	x	x
On-Demand Hot Water Heater	x	x	x
36 Gallon Water Tank	x	x	x
Dual 11 Pound Propane Tanks	x	x	x
Reinforced Fridge / Prep Table Mounted To Rear Door w/ 12V Power	x	x	x
Fold-Down Stainless Steel Prep Table Mounted On Spare Tire Rack		x	x
STORAGE			
Shower & Hose Access w/ Independent Hot & Cold Water Controls	x	x	x
Four Aluminum Side Boxes w/ Interior LED Lights	x	x	x
Heavy Duty Roof Rack T-Slot Crossbars	5	5	5
Tongue Box Top Storage Rack w Tie-Down Points	x	x	x
Heavy Duty Aluminum Expedition Side Rack System	x	x	x
Squatch Box - Holds (2) Solar Panels And Custom Camp Table			x
SUSPENSION & WHEELS			
Independent Suspension System w/ Coilover Shocks & 5" Of Travel	x	x	x
ARK 2" Articulating Coupler	x	x	x
ARK XO Off-Road Trailer Jack	XO 500	XO 500	XO 750 Black
ARK Drop Down Corner Steadies Integrated Into Bumper		30"	33" XO
10" Electric Brakes	x	x	x
BF Goodrich 285/65/R17 All-Terrain T/A Tires w/ Full Size Spare	x	x	x
17" Wheels	Black Steel	Black Steel	Method Black Aluminum
Parking Brake	x	x	x



COLORS

All Sasquatch Expedition Campers come standard with a Hammertone finish; an orange peel texture that is more resilient to cosmetic damage. From standing out to blending in, choose the color of your Sasquatch Expedition Camper that suits you.*

** True colors can vary from colors on this page due to lighting and screen display settings.*

BLUE	WHITE W/ BLACK VEIN
RED	BLACK
WHITE	MOSS GREEN
DESERT SKY	BRONZE
LIGHT GREY	IRON GREY



To Explore
There

Built
Here

LIVE LEGENDARY

Sasquatch Expedition Campers are handcrafted in the heart of the Rocky Mountains at an elevation of 9,318' and built on the belief that expedition campers should be born in the same terrain they were meant for. Built rugged, for the rugged, all campers come with an industry-leading warranty.